

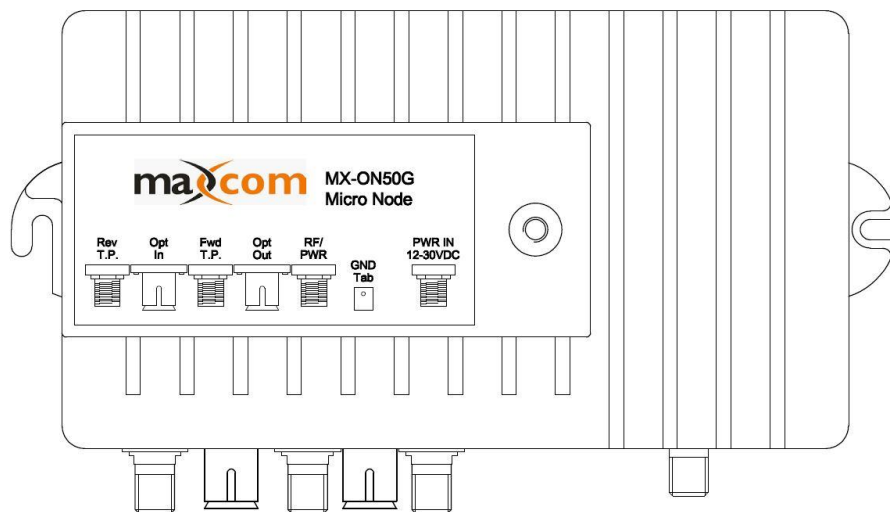

MX-ON50G FTTB Bi-directional Optical Node

Features

- 1 GHz with 50 dBmV output
- Flexible RF Level and Slope Control Features
- DFB 3mW Return Laser
- Available with optional 16 CWDM Wavelengths
- Four Diplex/Frequency splits available
- LED indicators
- Excellent Performance Specs
- Compact Design
- Flexible Powering Options



SYMBOL	PARAMETER	CONDITIONS	MIN	TYP	MAX	UNIT
Forward Receiver						
λ	Optical Wavelength		1290	1550	1650	nm
Vopt.in	Monitor Voltage	$\lambda=1550$		1		mW/V
Pin	Optical Input Power		-6	-1	+2	dBm
F	Frequency Range	Note1	f_H		1002	MHz
FL	Flatness of Frequency Response	$f=f_H$ to 1002MHz		± 1		dB
S22	Output Return Loss	$f=f_H$ to 1002MHz	14	16		dB
Lo	Reference Output Level	@1002MHz		50		dBmV
	Slope			15		dB
	Optical Input Return Loss		45			dB
C/N	C/N	Forward path 78 ch analog CW (50~550 MHz) and digital channels (550~1002 MHz, RF level 10 dB lower) at -1 dBm optical input	51			dB
CTB	CTB				-65	dB
CSO	CSO				-60	dB
f	Equivalent Noise Input	$f=55$ MHz			7	pA/Hz
Return Transmitter						
λ	Optical Wavelength	CWDM		1550		nm
Wout	Optical Output Power		1	2	3	mW
LRin	RF Input Level		10		40	dBmV
F	Frequency Range	Note1	5		f_L	MHz
FL	Flatness of Frequency Response	$f=5$ to f_L MHz		± 0.75	± 1	dB
S11	Input Return Loss	$f=5$ to f_L MHz	14	16		dB
	Optical Output Return Loss		45			dB
General Parameters						
Itot	Total Current Consumption (DC)				10	W
Tmb	Operating Mounting Base Temperature	Humidity 5% to 95%, none condensing	-20		+55	°C
Dim	Dimensions	(LxWxH)	225x122x82			mm
			8.9x4.8x3.2			in

Note1: standard options ($f_L/f_H = 42/54, 65/85, 85/105$).





Diagram

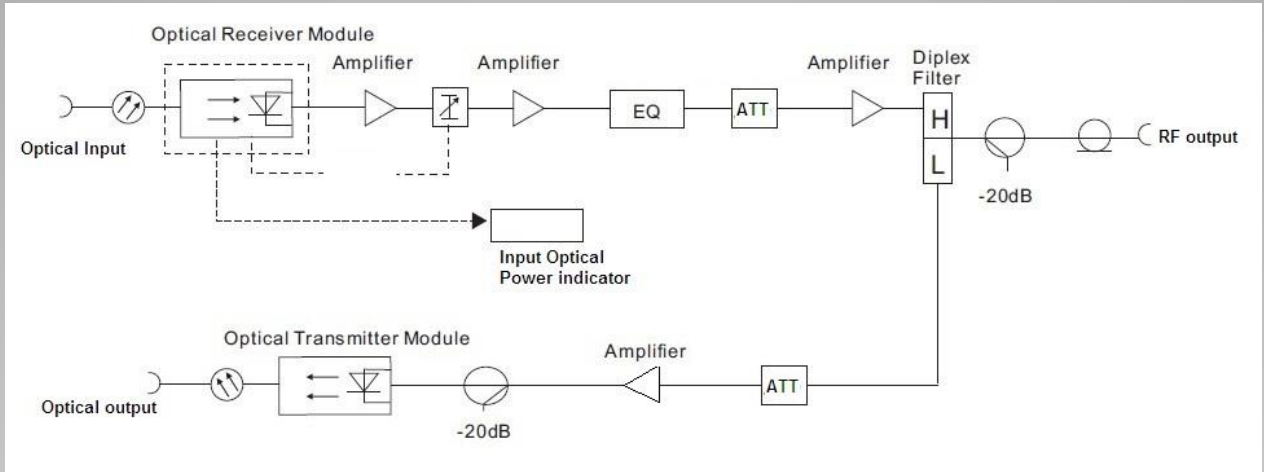

Ordering information

MX-ON50G-A-B-C



A	B	C
Transmit Power of DFB Return laser	Reverse Wavelength	Diplex Sub-Split MHz
D1: 1mW D2: 2mW D3: 3mW	Standard is 1550 31:1310nm 47:1470nm 49:1490nm 51:1510nm 53:1530nm 55:1550nm 57:1570nm 59:1590nm 61:1610nm *1270 to 1450nm Also available	45: 42/54 57: 55/70 68: 65/85 81: 85/105 *comes standard w/ 45 (42/54 MHz)

Units come standard with SC/APC connectors, 120VAC Power Supply (29 VDC output)

Uses standard JXP style attenuator pads and EQ's (1GHz)

Interior Illustration

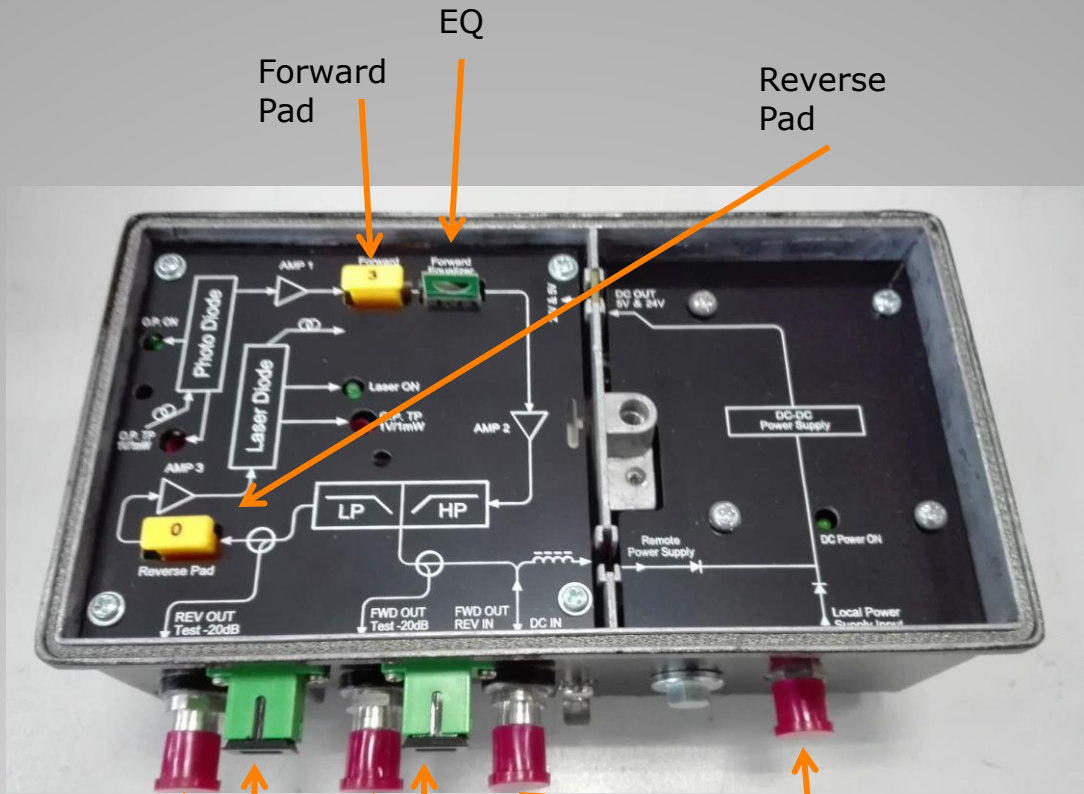

Return Path Test Point

Fiber input

Fiber Output

Primary Forward Output – Reverse Input – Unit may be powered at this port as well using an external power inserter

"F" Connector Output of Power Supply



Power Supply Included

Flexible Design
Interchangeable Pad and EQ for optimal
Level and Slope Control

- MX-ON50G Optical Node
- The MX-ON50 Series Optical Nodes are Designed for Maximum Versatility and Performance. They are ideal for fiber-to-the-building applications. The high RF output, available CWDM Return DFB Lasers, Gain and Slope control (equalizers included), offer the Technician the Flexibility Needed for Individual Customer Situations and Installations.
- Maxcom provides professional optical solutions for both long and short haul transport needs for point-to-point or point-to-multi point locations. Our engineers can help you with any project design and equipment needs. We offer an outstanding warranty on all of our products, along with strong technical support staff.
- Fiber optic technology is constantly changing and Maxcom's goal is to continue to provide the fiber optic solutions and services needed for a better tomorrow.



Provided by: Mega Hertz | 800-883-8839 | info@go2mhz.com | www.go2mhz.com

<https://www.go2mhz.com/product/optical-node-2/>