



## OPTICAL TRANSMISSION PLATFORM

### MX-T-EDFA Series Model V2.9

### Integrated RFoG Transmitter and Optical Amplifier



The MX-T-EDFA is a highly integrated, yet simple device specifically designed for Cable Telecommunication Systems deploying RFoG or RF Overlays in the FTTx environment with integrated filters supporting GPON and/or XG(S)PON (10G). Its small size and high density make it the ideal choice, particularly in tightly enclosed environments.

The 1RU 19" Rack Mounted Chassis can hold two modules. Each module has an integrated 1550 Transmitter and EDFA with PON ports. The modules accept a RF input and will provide up to +20 dBm optical power on each output port. Modules are available with 8 or 16 output ports, plus corresponding GPON/XG(S)PON ports. To keep things simple, it is plug and play! For your convenience, an optional External LED Controller/Display may be connected via USB, a Laptop may be connected, or the unit may be attached to your network. These connection types provide simple adjustment of the optical output power along with monitoring.



## FRONT PANEL

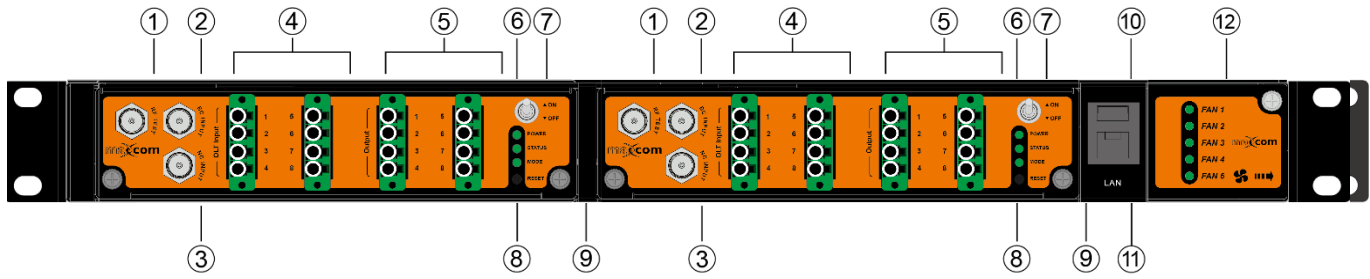

### RF Port

No.	Name	Description
1	RF TEST PORT -20 dB	F-female
2	BC Input (Broadcast)	F-female
3	NC Input (Narrowcast)	F-female
4	OLT Input/output (GPON & 10G XGSPON Passthrough)	LC/APC
5	Optical Output Ports	LC/APC
7	Laser Switch	Up = ON / Down = OFF
6	Power	On = Green / Off = No light
8	Status	Green = RF good, Laser On / Red Flashing = Warning, RF input low / Red = Laser Switch Off
9	Mode	Green (this function reserved for future)
12	Fan	Green = Fan Operational / Red = Warning
10	Communication interface	USB
11	LAN	RJ-45

## REAR PANEL



Image shown with 110 VAC Power Supplies

Ground Connection



TX-EDFA Module (8 outputs with 8 PON ports)



Rear of TX-EDFA Module



External LED Control





## Intuitive Web Interface

The Maxcom Optical Transmission Platform uses a web interface GUI (Graphic User Interface) for control, display, and monitoring. The device/equipment management software allow the user easy access and visibility to the modules, chassis, power supplies, and fans. It allows the user to monitor a number of parameters simultaneously, such as laser power, RF and optical signal strength, temperature, voltages, etc...

For quick access, simply plug a laptop into the RJ-45 port on the front panel of the chassis. Open a web browser. The default IP address is 192.168.1.50. Enter **192.168.1.50** into the browser and hit enter. The Maxcom Screen should appear with a log-in box. The default username is: **admin**, the default password is: **admin**.

In the left column, you may select the device, such as the system info from the chassis, the fan module, the power supply modules or the TX-EDFA modules in slot 1 or slot 2.

You may select slot 1 or 2 to adjust the optical output power level by selecting a value between +20 dBm and +14 dBm.

Note that you may also change the IP address to your preference. Make sure you select save to execute any changes.

\*The unit may also be controlled or monitored using an optional External USB plug-in LED Control

\*The unit will also operate without a laptop or external control, simply turn it on to plug-n-play  
Optical output power will default to the last setting or factory default to the highest available if not set.



# WAVELENGTH DETAIL for GPON, xGPON, and RFoG:

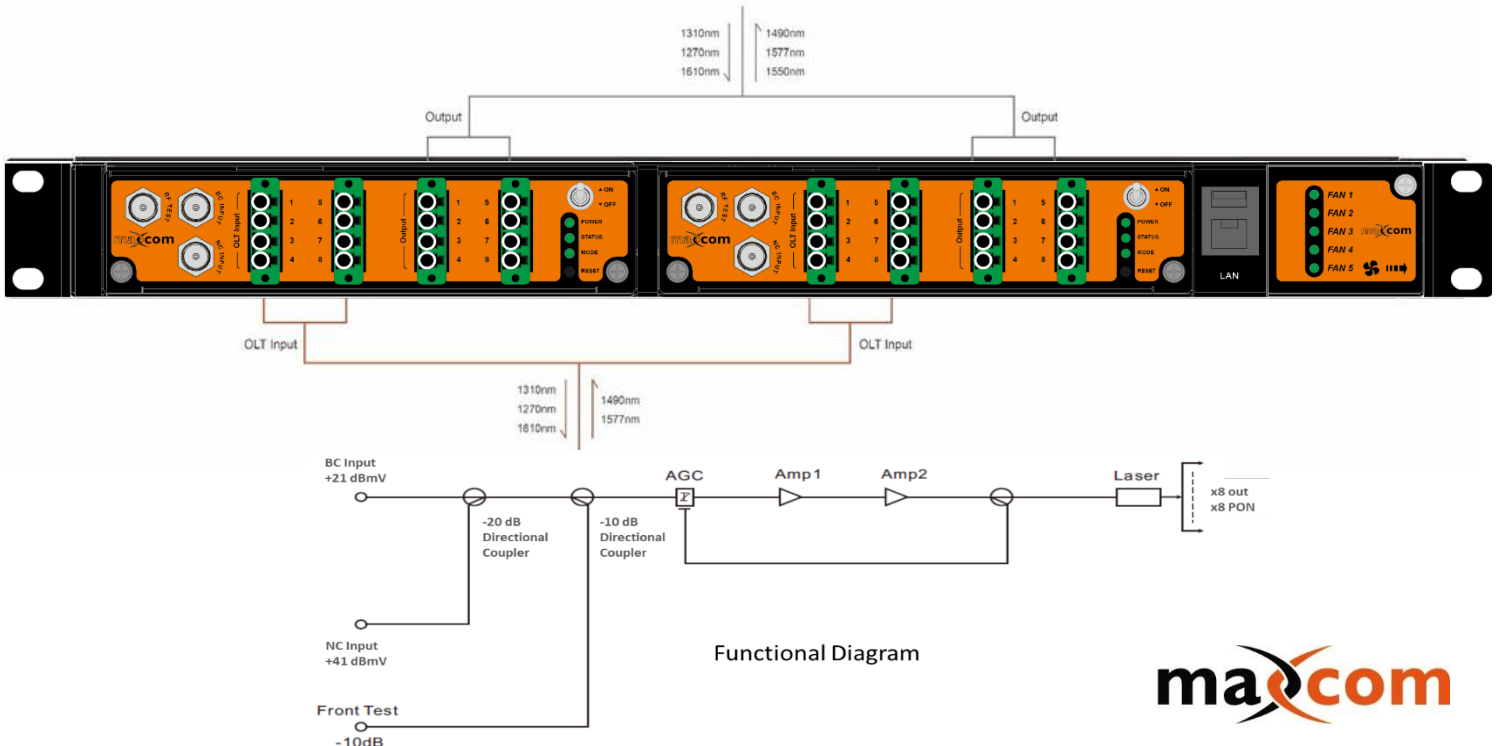
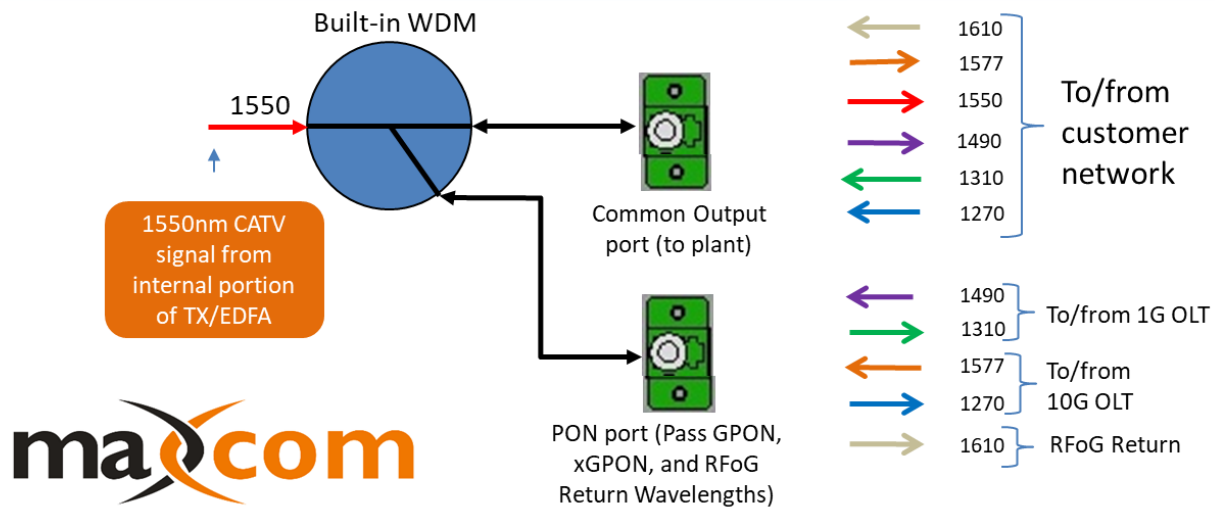
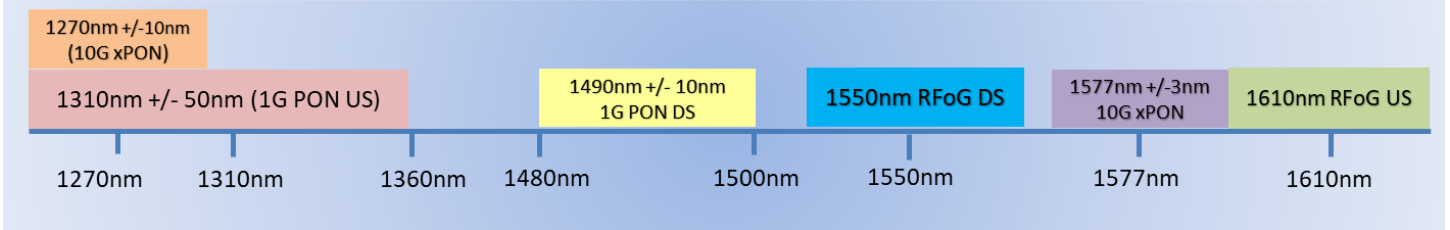
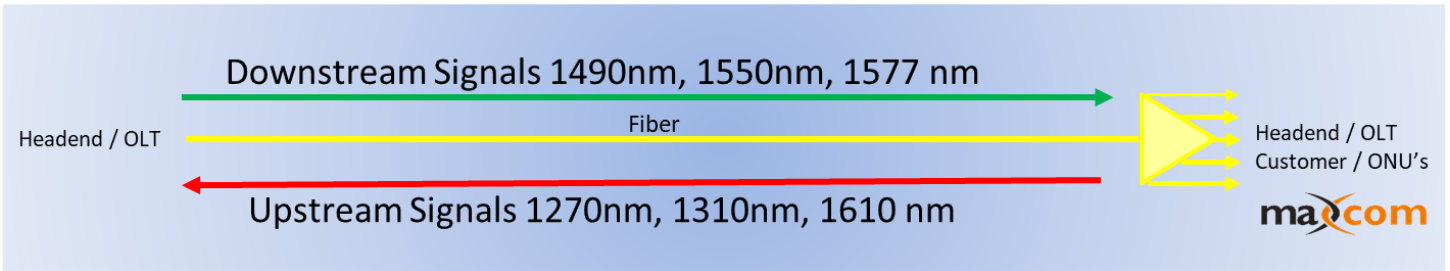

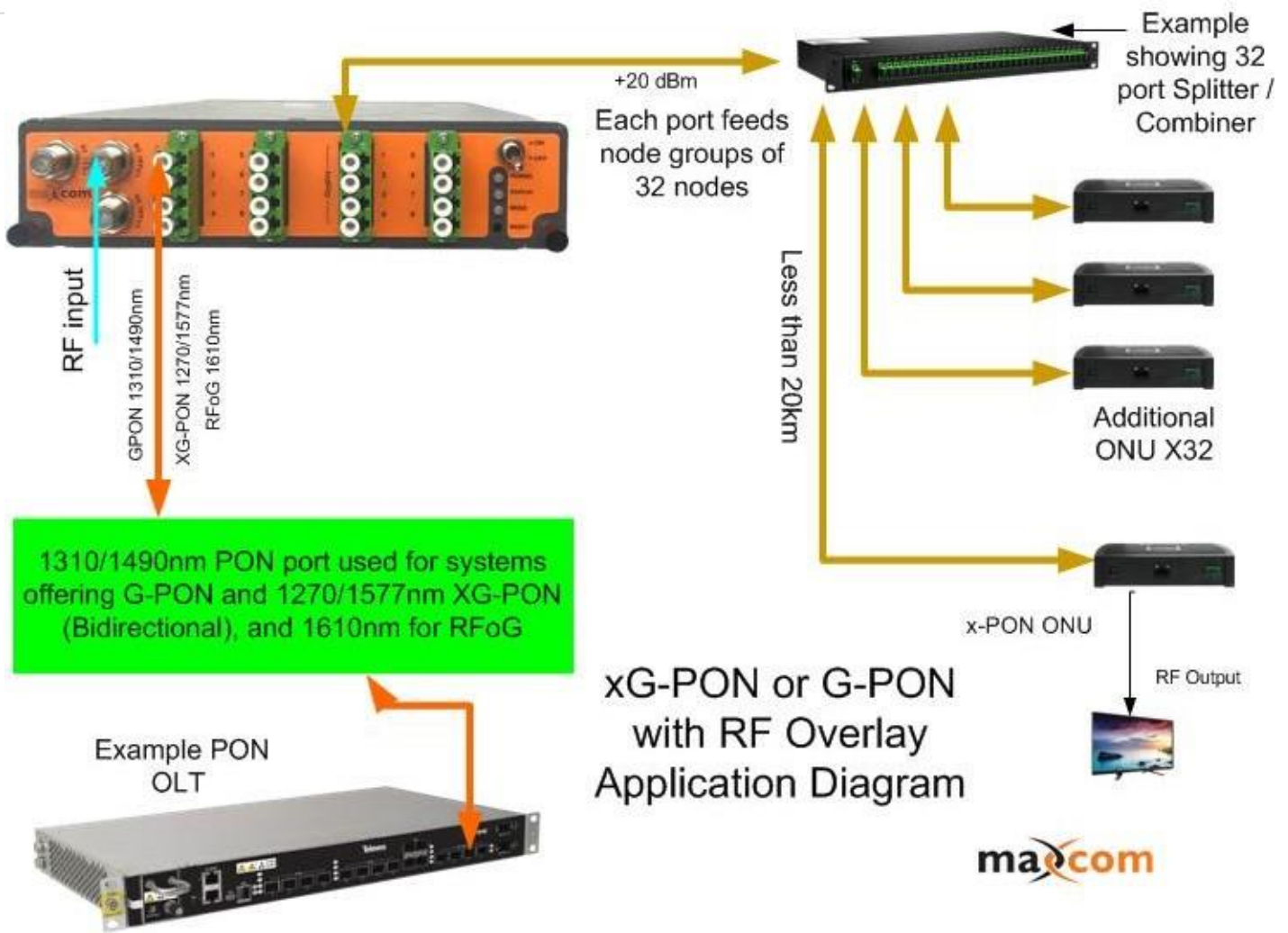

### ORDERING INFORMATION

Part Numbers:	Description:
MX-T-EDFA-8x20-PON	Integrated 1550 transmitter with built in EDFA, broadcast and narrowcast RF input, 8 output ports at 20dBm, plus 8 PON ports, requires chassis & PS
MX-T-EDFA-16x20-PON	Integrated 1550 transmitter with built in EDFA, broadcast and narrowcast RF input, 16 output ports at 20dBm, plus 16 PON ports, requires chassis & PS
MX-EDFA-8x20-PON	Module - EDFA 8 outputs with +20 dBm each, and 8 x/PON ports, requires chassis & PS
MX-EDFA-16x20-PON	Module - EDFA 16 outputs with +20 dBm each, and 16 x/PON ports, requires chassis & PS
MX-C-T-EDFA-E	1RU Chassis (Casing) empty, no PS, or fans
MX-T-EDFA-PS11	Accessory, Hot Swappable Power Supply 110 VAC
MX-T-EDFA-PS48	Accessory, Hot Swappable Power Supply -48 DC
MX-T-EDFA-FAN	Accessory, Hot Swappable Fan Tray
MX-C-T-EDFA-(/D11 or /D48)	Chassis, 1RU, Tx-EDFA combo, includes dual 110 VAC power supplies & fan tray, holds 2 TX-EDFA modules
MX-T-EDFA-LED	Chassis, 1RU, Tx-EDFA combo, dual -48DC power supplies & fan tray, holds 2 TX-EDFA modules

## Assembly and Power Connections

- A. Equipment should be mounted in a 19-inch chassis or cabinet.
- B. The optical amplifier is designed to work within the temperature range  $-5^{\circ}\text{C}\sim 50^{\circ}\text{C}$  ( $23^{\circ}\text{F}\sim 122^{\circ}\text{F}$ ). Maxcom suggest a target environment temperature of  $25^{\circ}\text{C}$ ( $77^{\circ}\text{F}$ ). Humidity should not exceed 85%. A dust free environment is desirable, however if dust is present, clean the fans periodically as needed to maintain good air flow and cooling to prevent the unit from overheating.
- C. The equipment may operate with AC or DC power supplies and uses optional dual power supplies for redundancy.
- D. Establish a good ground connection to the chassis. If using AC power, according to international standards, 120VAC connections adopt three-wire systems, the center wire is the ground.
- E. Clean Optical Connectors before use.

## Fiber Connections

Cleaning fiber-optic connectors can help prevent interconnect problems and therefore, aid system performance. When optical connectors are disconnected and reconnected, the fiber surface may become dirty or scratched. The goal of cleaning the fiber optic connectors is to remove all dust and contaminants without leaving any residue.

**DO NOT** connect or disconnect optical jumpers/connectors when unit is on and in operation (switched on)! Connector surface may become damaged or burned by HIGH LASER POWER Level. Unit must be switched to off position prior to any type of connection being made to unit. In case of accidental damage where levels are displayed normally on screen, but low on the output port, the optical connector may be changed or replaced to restore normal levels.



### CAUTION:

For high power optical levels, in particular to high power optical transmitters and EDFA's, extra caution should be used. Fiber connectors can be burned or melted, arcing may occur, damage may occur to any device that a connector comes in contact with. Extreme caution and safety practices should be observed to avoid contact with eyes and skin. To avoid injury and microscopic damage to fiber mating surfaces, turn off optical power before making or breaking optical connections



## PRODUCT FEATURES

- \* Integrated Optical Transmitter with Optical Amplifier
- \* Pluggable Modular Design
- \* Compatible with any FTTx, PON Technology
- \* XGPON, GPON, EPON, RFoG, RF Overlay
- \* Each Output Optical Power up to +20 dBm
- \* Dual Power Supplies with 1+1 Backup

Optical  
Transmission  
Platform

MX-T-EDFA  
Series

\*Also Available without  
Integrated Transmitter  
(w/EDFA Modules Only)

## TECHNICAL INDEX

### RF feature

Performance	Min.	Typ.	Max.	Supplement
Work bandwidth (MHz)	47		1000	
Input range (dBmV)	15		28	AGC
Input range (dBmV)	15		22	MGC
CNR (dB)	51			back-to-back
CTB (dB)	63			back-to-back
CSO (dB)	60			back-to-back
BER (dBm)		1E-9		
RF test point level relative to RF input		-10		

### Optical feature

Performance	Min.	Typ.	Max.	Supplement
Pass Wavelength (nm)	1545		1562	Forward CATV TX
Reflect Wavelengths (nm)		1310 / 1490		GPON
Reflect Wavelengths (nm)		1270 / 1577		XGPON
Reflect Wavelengths (nm)		1610		RFoG Return
Insertion Loss (dB)		1		
Number of output port	4	8	16	
Each port output power (dBm)	14		20	Adjustable
Output power adjustable range (dBm)		-6		APC
Fiber connector			LC / APC	

### General feature

Performance	Min.	Typ.	Max.	Supplement
Web Interface or SNMP		RJ45		
Communication interface		USB		External LED Controller
Power consumption (W)			120	
Power supply (VAC)	90	110	265	
Power supply (DC)		-48		
Operating temp. (°F)	23		121	
Storage temp. (°F)	-40		185	
Relative humidity (%)	5		85	
Size (inch)		19" X 13.8" X 1.75"		Chassis
Size (mm)		483 x 350 x 44		Chassis

All product and company names mentioned in this data sheet are the property of Maxcom Corp and their respective companies.

\*All product, product specifications and data are subject to change without notice to improve reliability, function, design or otherwise.

Maxcom Confidential and Proprietary

