

CableOS[®] Reef

DENSE R-PHY SHELF



The Harmonic CableOS Reef Dense Remote PHY Shelf (RPS) is a 2 RU indoor platform for networks tasked with delivering and fully converging data, voice and video services over coax and defining a new category of Distributed Access Architecture (DAA).

Fundamentally changing the business dynamics of cable delivery, CableOS introduces cable operators to unprecedented scalability, agility and cost savings. The end-to-end solution supports centralized and distributed cable access architectures that enable the fast deployment of IP-based data, voice, video and legacy services — and sustainable capacity growth. All CableOS components work together to resolve space and power constraints in the headend and hub, eliminate dependence on hardware upgrade cycles, and provide multi-dimensional scaling. The Reef Remote PHY Shelf is a new addition to Harmonic’s CableOS cable access solution.

Dense, compact and cost-effective, the Reef RPS houses up to nine modular linecards, each with two independent Remote PHY devices (RPD’s) of 1DSx2US ports, for a total of 18 service groups. The Reef supports complete service convergence for an end-to-end service deployment, including data, video and legacy out-of-band services. All services can be combined and transmitted from a single RF port connecting directly to lasers, saving space, power and wiring, and greatly simplifying indoor facilities by eliminating splitting and combining while leveraging the existing outdoor plant elements.

Each linecard houses two independent RPD’s based on Harmonic’s industry leading Pebble RPD design, supporting a spectrum of up to 1218 MHz, with DOCSIS 3.1 OFDM in the downstream or OFDMA in the upstream. With the Reef’s modular architecture, each Reef can be populated with one to nine linecards, each agnostic to the other and each independently hot-swappable. Each linecard can also support configurations of 1DS x 1US or 1DS x 2US ports and can even have up to 4 US ports associated with a single DS port.

For added reliability, the Reef supports a dual redundant power supply option, which can be AC or DC, while still delivering the maximum density of 9 linecards.



HIGHLIGHTS

- 2 RU modular chassis hosting up to 18 RPD’s at total density of 9RPD/RU
- 9 linecards per chassis, each with 2 RPD’s
- Passive chassis with full hot-swap design
- 2 redundant, load-sharing PSU’s, with AC or DC powering options
- Low power consumption: 35W per RPD, 620W for whole chassis
- Configurable DS power and tilt
- Supports DOCSIS 3.1 DS
- Complies with CableLabs MHA v2 spec for R-PHY architecture
- PTP (IEEE 1588) synchronization
- Highly reliable mechanical design, based on the field-proven NSG9000 chassis

World-Class Service and Support

With thousands of successful installations, Harmonic possesses unique, extensive knowledge of the cable edge environment and unsurpassed expertise in managing live production networks. Harmonic technical support and field engineers possess decades of experience in the cable industry and have the ability to go far beyond optimal deployment strategies and troubleshooting. The Harmonic Global Service and Support organization also understands the intricacies of every ancillary system touched by the edge network, from back-office video control planes to IP backbones to deep-fiber HFC nodes.

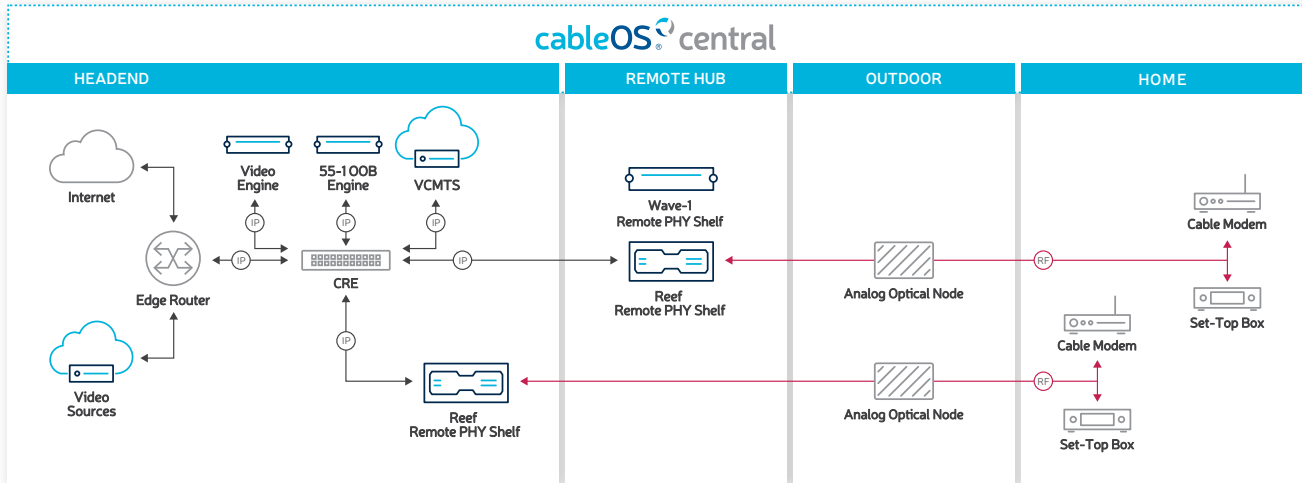

Provided by: Mega Hertz | 800-883-8839 | info@go2mhz.com | www.go2mhz.com

