

Product Overview

The **Falcon-RX** is an essential element in delivering on the promise of 5G. Through high capacity, low latency transport and high precision synchronization, the **Falcon-RX** enables 5G RAN operation at its optimal capacity, on both telecom and enterprise environments.

The **Falcon-RX** combines the best of breed of the Transport and Timing worlds, in a single powerful package. Both elements are critical for 5G fronthaul deployments, along with support for the latest O-RAN architectures and recommendations.

The **Falcon-RX**'s Timing toolbox includes a complete set of capabilities, including GNSS based PTP GM/BC/TC/OC (sub nanosecond accuracy, Class C/D performance), along with robust SyncE and other sync interfaces. The system's timing is orchestrated via Fibrolan's user friendly SyncCenter.

The **Falcon-RX** series is equipped with a total of 20xSFP+/SFP28 ports, with configurable port setup for up to 200Gbps/FDX (400Gbps switch fabric capacity). All ports can operate at full wire speed, at any packet size (including Jumbo frames).

The **Falcon-RX** offers advanced Quality of Service (QoS) features including classification and mapping based on layer 1 through layer 4 attributes, port and queue policing and shaping, with highly flexible scheduling schemes.

Support for Time Sensitive Networks (TSN) makes the **Falcon-RX** an even greater fit for fronthaul, as well as industrial environments (Industry 4.0, IIoT), where 5G infrastructure serves the automation of factories.

- LTE/5G xHaul Transport and Timing switch
- Integrated PTP Grandmaster
- Compatible with O-RAN architectures
- High capacity, low latency
- Extensive Sync and Timing with SyncE and PTP (PTRC/GM, BC, TC)
- Sub nanosecond timestamping, Class C/D performance
- Time Sensitive Networking support
- Based on 4th generation Falcon architecture
- Advanced QoS and service level traffic management
- Advanced OAM and management capabilities
- Multiple protection mechanisms for link, path, and ring service resilience



Multiple protection schemes help cover any deployment topology (linear, star, ring) and deliver the reliability required for critical infrastructure such as 5G. In addition, L3 forwarding is supported (static; dynamic routing in future SW releases).

The system implements effective OAM tools, for monitoring, alarming, analysis and troubleshooting of the system and the forwarding plane as well as the synchronization plane.

The **Falcon-RX** is built in a robust 19"/1RU housing, allowing the installation of hot swappable redundant AC and/or DC power supplies.

Technical Specifications

Interfaces & Indicators

- Ethernet (data-plane):
 - 12 x 1/10G (SFP/SFP+)
 - 8 x 1/10/25G (SFP/SFP+/SFP28)
 - Any combination of active ports allowed (up to 200G)
 - Supported SFPs: MM, SM, SFS, xWDM, Copper
- Sync & Timing:
 - All Ethernet ports support PTP, SyncE and NTP
 - GNSS antenna in (TNC, active, 5VDC)
 - 3 x external 1PPS/10MHz (SMA)
 - ToD/1PPS (RJ45)
 - BITS (RJ48)
- Management (OOB):
 - 1 x 10/100/1000BaseT (RJ45)
 - 1 x RS232 (console, RJ45)
 - 1 x USB (console)
- 2 x SFP for future enhancements
- LEDs
 - Link/Activity (per port)
 - Sync
 - GNSS
 - CPU
 - BITS, ToD
 - Aux.
 - Power

Architecture & Forwarding

- Hybrid (ASIC-FPGA) HW architecture
- Performance: wire-speed, on all ports, all frame sizes
- Switching fabric: 400Gbps (200G/FDX), non-blocking
- MTU: 10K bytes
- MAC table: 32K addresses
- VLANs: 4K concurrent
- Provider bridging: 802.1ad (Q-in-Q)
- Private VLANs
- IP routing:
 - Static routes
 - Dynamic in Future SW releases
- Time Sensitive Networking:
 - Time-aware Scheduling (IEEE802.1Qbv)
 - Frame Preemption (IEEE802.1Qbu, IEEE802.3br)
 - Ingress gating/policing/checking (IEEE802.1Qci)
 - gPTP (IEEE802.1AS)
 - FRER (IEEE802.1CB)
 - Cut through mode
- L1-L4 ACLs
- Multicast:
 - IGMPv3 snooping
 - MLD snooping
 - Up to 8K MC groups

PTP/IEEE1588

- Functions:
 - Grandmaster (PRTC)
 - Boundary Clock (Class C/D)
 - Ordinary Clock (M/S)
 - Transparent Clock (Class C/D)
- Profiles supported:
 - Telecom Frequency (G.8265.1)
 - Telecom Phase (G.8275.1, G.8275.2)
 - Default (IEEE1588)
 - AVB (802.1AS)
 - Custom
- Modes supported:
 - 1 and 2 step
 - L2 Multicast
 - L3/UDP Unicast/Multicast
 - Mixed transport modes
 - E2E and P2P delay
 - VLAN tagging
- Slave capacity:
 - Up to 256 Unicast @ full packet rate
 - Support for max packet rates for Sync, DelReq, Announce
- HW timestamping: <1nsec resolution

Other Timing & Sync Features

- Synchronous Ethernet (SyncE):
 - G.8261, G.8262
 - ESMC (G.8264)
- GNSS:
 - 32 channels
 - Multi-constellation (GPS, GLONASS, Galileo, Beidou)
- ToD/1PPS:
 - Input/output
 - NMEA, G.8271
- SyncCenter
- NTP
 - Client
 - Server (future upgrade to HW based server)
- External Sync:
 - Input/output
 - 1PPS/10MHz
- Local clock:
 - Built-in Stratum 3/3E clock (model dependent)
 - Optional Rubidium Clock module (pluggable)

Quality of Service

- Classification based on L1-L4 information
- Ingress policing per port/queue
- Hierarchical shaping and scheduling
- Priority based flow control (802.1Qbb)
- Scheduling: Strict, DWRR, hybrid
- 4 drop precedence levels
- WRED and tail drop for CA
- P-bit and DSCP remarking
- Storm control: UC, MC, BC
- QoS Control Lists

Protection

- Link:
 - Link aggregation: static or LACP
- Linear (path) protection: G.8031
- FRER
- Ring protection: G.8032v2
- Spanning tree: STP, RSTP, MSTP
- Loop protection

OAM & Diagnostics

- IEEE802.3ah link OAM
- IEEE802.1ag CFM (HW assisted)
- Ping (IPv4/v6)
- Traceroute (Ipv4/v6)
- Throughput metering
- SFP diagnostics (SFF-8472)
- Traffic mirroring and remote mirroring
- sFlow

Management

- Interfaces:
 - CLI: Console, Telnet, SSH
 - SNMP: v1/v2c/v3, extensive MIBs
 - Web: HTTP/HTTPS
 - Management VLAN
 - IPv6 management
- Authentication:
 - RADIUS, TACACS+
 - Multiple local users
 - User access levels (15)
 - Management ACLs
 - 802.1x (port/MAC based)
- DHCP client, relay, server, snooping
- Link discovery: LLDP, LLDP-MED, CDP snooping
- CPU sub-system:
 - Dual-core, @1GHz, ARM
 - 1GB DDR, 4GB flash memory
- Operations:
 - Remote System Update (TFTP or Web)
 - Configuration upload/download (TFTP or Web)
 - Text based config files
- Alarms:
 - SNMP traps
 - Syslog (internal and remote server)
 - CLI events
- Remote temperature reading & alarm
- Per port and queue detailed statistics
- RMON

Power & Environmental

- Dual, redundant, hot swappable power supplies
- AC/DC: 100-240VAC, 50/60Hz or 125VDC
- DC: 20-60VDC, ST connector
- Power consumption:
 - Maximum: <65W; typical: <55W
- Operating temperature:
 - Standard: 0°C ÷ +50°C (32°F ÷ 122°F)
 - Extended: -40°C ÷ +65°C (-40°F ÷ 149°F)
- Storage temperature: -40°C ÷ +80°C (-40°F ÷ 176°F)
- Humidity: 10-90%, non-condensing

Physical

- Dimensions (HxWxD):
 - 44 x 440 x 305 mm (1.73 x 17.33 x 12.01 inch)
- Mounting:
 - Desktop
 - Rack
- Weight: ~5.5Kg (12.2 lb)
- Accessories:
 - Power cable
 - RS232 cable (console)
 - USB cable (console)
 - Rack mounting (w/ grounding) kit

Regulatory & Compliance

- Safety:
 - IEC EN60950-1
- CE
- RoHS
- EMC:
 - FCC CFR 47 part 15, subpart B, Class A
 - EN 300 386 V1.3.3: 05



Typical Application: LTE/5G fronthaul/backhaul Convergence

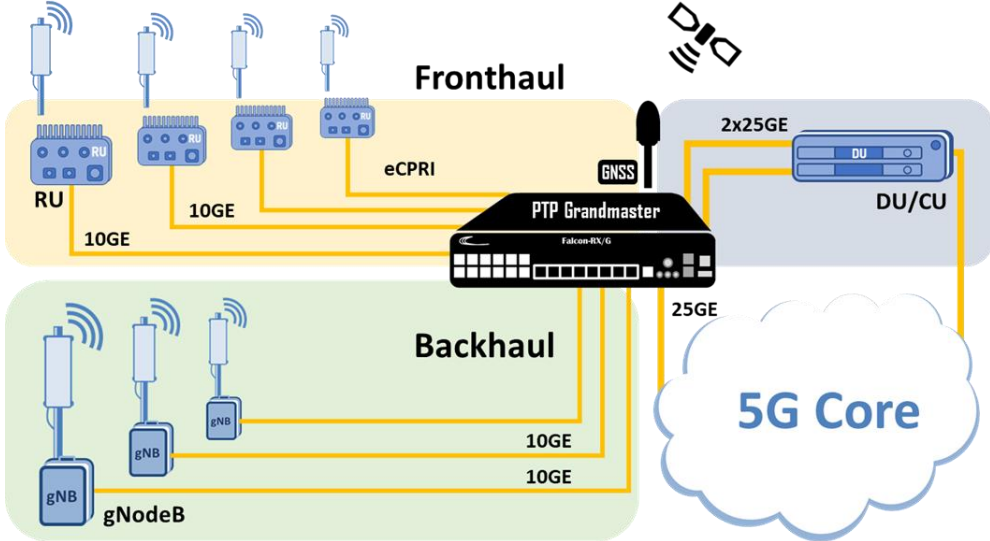

Ordering Information

Model	P/N	Description
Falcon-RX/812/G/A	7160	Timing Aware xHaul Switch, 12x10G (SFP+), 8x25G (SFP28) ports, Advanced Timing spec w/ GNSS Rx, 1 removable AC power supply (FPS10012/A)
Falcon-RX/812/G/D	7161	Timing Aware xHaul Switch, 12x10G (SFP+), 8x25G (SFP28) ports, Advanced Timing spec w/ GNSS Rx, 1 removable DC power supply (FPS10012/D)
FPS10012/A	7106	Redundant power supply, AC/DC (100-240VAC/125VDC), 50 to 60Hz, 100W
FPS10012/D	7107	Redundant power supply, DC (20-60V), 100W

Specifications are subject to change w/o prior notice

We've got Timing for you!



Provided by: Mega Hertz | 800-883-8839 | info@go2mhz.com | www.go2mhz.com
<https://www.go2mhz.com/product/5g-xhaul-timing-aware-switch-ntp-grandmaster/>