

500DA2Q-HD, 500DA2Q-HD-N

HD/SD SDI Dual Reclocking & Non-reclocking Distribution Amplifier (2-1x4)



The 500DA2Q-HD Dual HD Reclocking Distribution Amplifier provides the highest density DA in the industry allowing up to 32 HD or SDI Distribution amplifiers in a 3RU rack space. It provides inexpensive distribution of your ST 292-1 (1.5Gb/s), SMPTE ST 259-1 (143 to 360Mb/s), SMPTE ST 344-1 (540Mb/s), DVB-ASI or SMPTE ST 310-1 (19.4Mb/s) or any other SDI signal within the 143Mb/s to 1.5Gb/s range.

The 500DA2Q-HD features two auto-equalized inputs and can be configured either as a single DA with eight reclocked outputs or as two separate DAs with four outputs each. In the case of dual operation, each DA can be individually set via jumpers for either reclocking or non-reclocking.

The 500DA2Q-HD is housed in the 500FR exponent frame that will hold up to 16 modules.

Features & Benefits

- Normal mode for SMPTE ST 292-1 (1.5Gb/s) SMPTE ST 259-1 (143-360Mb/s) or SMPTE ST 344-1 (540Mb/s) signals - autodetects correct bit rate
- Jumper selectable mode for DVB-ASI
- Jumper selectable non-reclock mode for SMPTE ST 310-1 (19.4Mb/s) signals or any other SDI signal within the 143Mb/s to 1.5Gb/s range
- Configurable as 1 DA with 8 outputs or 2 DAs with 4 outputs each
- Fully hot-swappable from front of frame with no BNC disconnect required
- Independent isolated output drivers to ensure no cross channel loading effects (i.e. no need to terminate unused outputs)
- Module health and 2x4 Mode Status LEDs
- Reclocker(s) Locked, Carrier Present and Video Standard LEDs for each DA channel
- Tally output on Frame Status bus upon loss of input signal
- VistaLINK[®] -capable for remote monitoring via SNMP (using VistaLINK[®] PRO) when installed in 500FR frame with 500FC VistaLINK[®] Frame Controller

Inputs

- Two inputs
- ST 292-1 (1.5Gb/s), SMPTE ST 259-1 (143 to 360Mb/s), SMPTE ST 344-1 (540Mb/s), DVB-ASI or SMPTE ST 310-1 (19.4Mb/s)
- Auto equalization to 100m Input A, 90m Input B (Belden 1694A) @ 1.5Gb/s

Outputs

- Four reclocked outputs per input
- Jitter < 0.2 UI

Card Edge LEDs

- Module Health Status
- 2x4 mode operation
- Reclocker rate detection
- Reclocker Locked
- Carrier Present

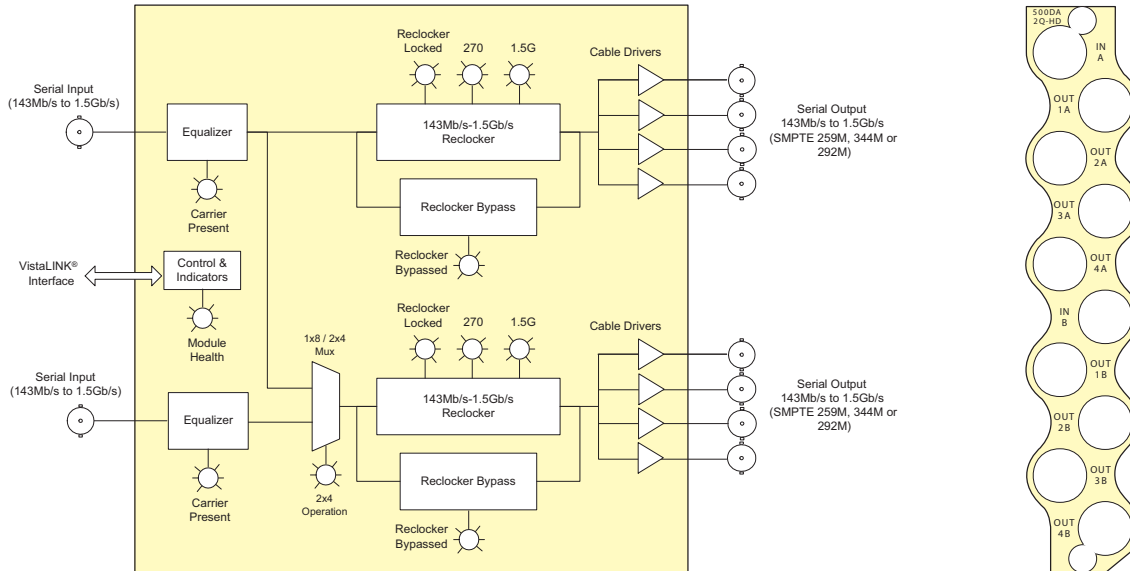

Specifications

Serial Video Input:

Standards	
Reclocked:	SMPTE ST 292-1 (1.5Gb/s), SMPTE ST 259-1 (143 to 360Mb/s), SMPTE ST 344-1 (540Mb/s), DVB-ASI
Non-reclocked:	SMPTE ST 310-1 (19.4Mb/s) Any SDI signal in the 143Mb/s to 1.5Gb/s range
Connectors:	2 BNC per IEC 61169-8 Annex A
Equalization:	
Input A:	Automatic to 100m @ 1.5Gb/s with Belden 1694A or equivalent cable
Input B:	Automatic to 90m @ 1.5Gb/s with Belden 1694A or equivalent cable
Return Loss:	> 15dB up to 1.5Gb/s

Serial Video Outputs:

Number of Outputs:	(mode set by jumper)
2x4 Mode:	4 reclocked from each input Reclockers can be bypassed separately for each input
1x8 Mode:	8 reclocked from Input A (1) Reclockers can be bypassed
Connector:	BNC per IEC 61169-8 Annex A
Signal Level:	800mV nominal
DC Offset:	0V ±0.5V
Rise & Fall Time:	200ps nominal
Overshoot:	< 10% of amplitude
Return Loss:	> 15dB up to 1.5Gb/s
Jitter:	< 0.2 UI

Electrical:

Voltage:	+12V DC
Power:	6W
EMI/RFI:	Complies with FCC Part 15 Class A EU EMC Directive

Physical (number of slots):

1

Ordering Information

500DA2Q-HD	HD/SD SDI Dual Reclocking Distribution Amplifier (2-1x4)
500DA2Q-HD-N	HD/SD-SDI Dual Non-Reclocking Distribution Amplifier (2-1x4)

Enclosures
500FR
S501FR

exponent
Compact High Density Distribution Frame
Standalone enclosure

Accessories

500FC	VistaLINK [®] Frame Controller
CP-2116E-H	Remote Control Panel
CP-2232E	Remote Control Panel