

## MAXLink™ 1550 nm Optical Amplifier HOA 7114 / 7117

### Product Description

The Harmonic MAXLink™ transmission system is a family of transmitters and optical amplifiers designed for 1550 nm based network applications. The MAXLink system provides a cost-effective solution for a variety of applications and architectures, including long haul applications that are beyond the reach of 1310 nm transmitters and fiber dense architectures which take advantage of high power optical amplifiers. In addition, this system is ideally suited for new, evolving transport architectures such as redundant rings, broadcast layer transmission, and hub interconnects used in broadband networks. The MAXLink product line consists of 1RU rack mount modules for 19" racks, including the HLT series of broadcast optical transmitters as well as a full range of optical amplifiers. The transmission system has been designed to complement Harmonic's PWRLink™ 1310 nm DFB transmitter family.

Full monitoring and configuration are available through the embedded SNMP agent and HTTP server.

### HOA 7114 / 7117 Typical Applications

#### Broadcast Services →

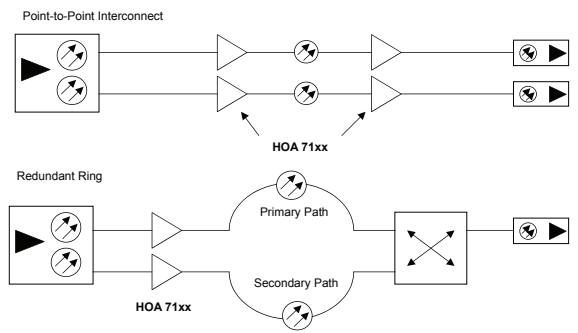

### Advantages

The HOA 7114 / 7117 Optical Amplifier is optimized for use with the Harmonic MAXLink product line and offers the following advantages:

- Low noise figure enables long distance transport with minimal signal degradation
- Convenient 1RU form factor
- Embedded SNMP agent (v1, v2c, v3)
- Support of SCTE, HMC MIBs
- Embedded Web (HTTP) server for user-friendly graphical interface

**Optical Output**

Wavelength Range	1540 to 1564 nm
Input Power Range	-10 to +5 dBm
Output Power	
HOA 7114	+14 dBm (25 mW)
HOA 7117	+17 dBm (50 mW)
Optical Power Adjustment Range	3 dB down from maximum
Noise Figure	< 4.3 dB at 0 dBm optical input
Optical Return Loss	> 40 dB
Polarization Sensitivity	< 0.5 dB
Backward ASE	10 dBm
Laser Shutdown	Interlock on fiber tray
Connector Type	SC/APC or E2000

**Powering**

AC Version	110/220 V 50/60 Hz
DC Version	-48 V
Consumption	60 W maximum

**User Interface**

Front Panel	Full numeric keypad and multi-line alphanumeric display
Optical Monitor Point	-16 dB relative to optical output, on front panel

**Network Management**

SNMP Protocol	v1, v2c, v3
HTTP Protocol	HTTP 1.1 (with Web browser-based authentication)

**Environmental**

Operating Temperature Range	-20° to +60° C / -4° to +140° F
Storage Temperature Range	-40° to +70° C / -40° to +158° F
Maximum Relative Humidity	85%, non-condensing

**Physical**

Dimensions	1.7" (1 RU) H x 19.0" W x 11.0" D 4.3 cm H x 48.3 cm W x 28.0 cm D
Weight	7.0 kg / 15.4 lbs

**Harmonic**

Provided by: Mega Hertz 800-883-8839  
 sales@go2mhz.com www.go2mhz.com