

Cisco uBR7100 Series Universal Broadband Router



The most cost-effective, feature-rich CMTS and integrated router for evolving Tier 2 or Tier 3 cable networks

Cable operators today are transforming themselves from entertainment companies into communication providers. The cable medium is well-suited to delivering high-speed Internet access and other Internet Protocol (IP) services to consumers, businesses, and others. While many users currently access the Internet via dial-up modems, they are quickly migrating to high-speed access alternatives.

The Cisco uBR7100 Series Universal Broadband Router allows smaller Tier 2 or Tier 3 cable operators to leverage an existing cable infrastructure to quickly and cost-effectively construct an advanced digital broadband network. This network—at the heart of which is the Cisco uBR7100 Series—is changing the landscape of the small cable operator market. The product brings tremendous value:

- Offering a standards-based product that delivers a feature-rich Data-Over-Cable Service Specification (DOCSIS) or European Data-Over-Cable Service Specification (EuroDOCSIS) Cable Modem Termination System (CMTS)
- Combining advanced routing capabilities with the CMTS through industry-standard routing hardware and Cisco IOS® Software that support unparalleled network services and applications

- Supporting an array of services geared to multi-unit (MxU) applications including hotels, convention centers, high-rise apartments, shopping malls, and universities
- Providing “one-stop” shopping that includes:
 - An integrated upconverter/modulator on the cable plant interface
 - An embedded dual 10/100 BaseT Ethernet network interface, with one optional interface such as Ethernet, FE, serial, high speed serial interface (HSSI), ATM, or POS
 - Support for property management systems and billing solutions; inclusion of the Cisco Network Registrar® solution to easily provision cable modems (CMs)
 - Configuration options that support two-way and telephone-return on the same downstream channel

Figure 1: The Cisco uBR7100 Series Universal Broadband Router



Offering New Horizons for Small Cable Operators

The Cisco uBR7100 Series consists of the:

- Cisco uBR7111 and Cisco uBR7111E which contain one downstream and one upstream port
- Cisco uBR7114 and Cisco uBR7114E which contain one downstream and four upstream ports

The Cisco uBR7111 and Cisco uBR7114 are CableLabs-qualified to DOCSIS 1.0 specifications. The Cisco uBR7111E and Cisco uBR7114E are tComLabs-qualified to EuroDOCSIS 1.0 specifications.

The Cisco uBR7100 Series Universal Broadband Routers integrate routing with a CMTS package that:

- Provides centralized network intelligence and control
- Uses scarce network bandwidth efficiently, including options that allow operators to engineer their networks based on cable plant spectrum characteristics and subscription and service level requirements
- Supports the creation of new pricing models that allow usage-based billing and quality of service (QoS) options that build increased customer loyalty
- Ensures security through DOCSIS and EuroDOCSIS 1.0 Baseline Privacy (BPI) or options for managed customer premises equipment (CPE) such as authentication, authorization and accounting (AAA) server and router

support. The system offers protection against spoofing to prevent subscribers from using source IP addresses not valid for the subnets to which they are connected

- Conserves valuable headend rack space, eliminating the need for an external upconverter/modulator or for two, separate co-located CMTS and router devices

The Cisco uBR7100 Series Universal Broadband Router is based on the industry-leading Cisco uBR7200 Series Universal Broadband Router. The product provides an alternative to the Cisco uBR7223 Universal Broadband Router for small cable deployments, but is designed mainly for the MxU market space.

Cisco uBR7100 Series Universal Broadband Router Applications

General Applications

The Cisco uBR7100 Series Universal Broadband Router sustains downstream and upstream traffic to and from DOCSIS or EuroDOCSIS compliant two-way or one-way cable modems, set top boxes, or other compliant devices. Figure 2 depicts a typical two-way application in which a cable operator allocates bi-directional channel capacity for residential Internet access, in addition to offering traditional cable TV services.

Figure 2: Typical Small Cable Operator Two-Way Application

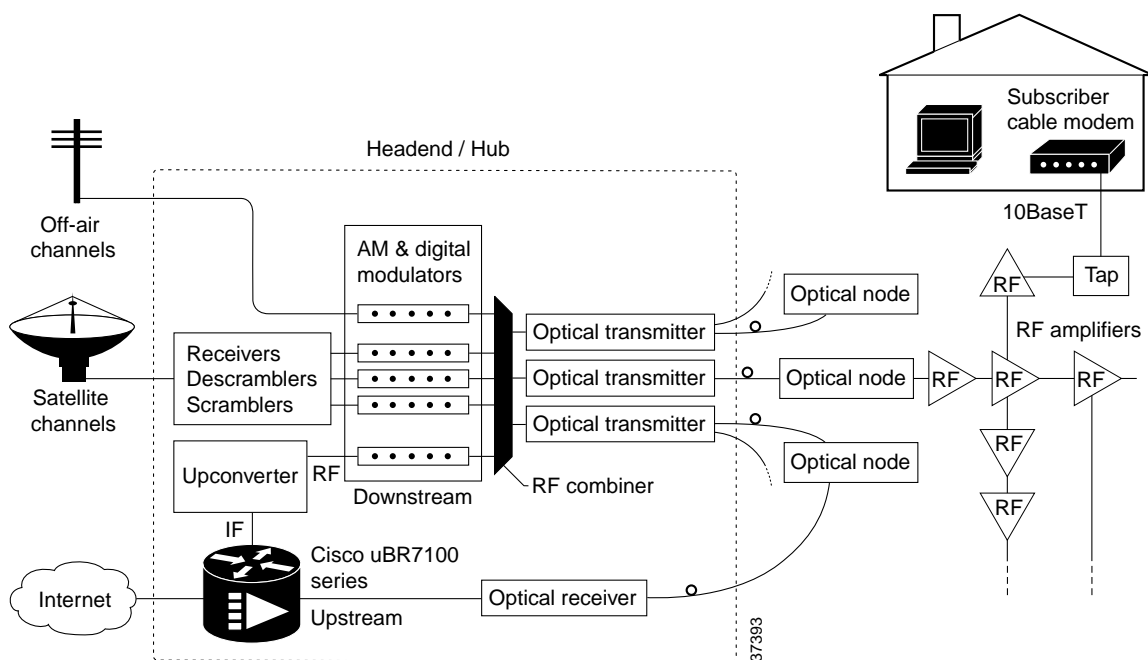

The Cisco uBR7100 Series supports telephone return over cable networks not yet two-way capable. Figure 3 depicts a DOCSIS telephone-return configuration. The network supports fast downstream access via the cable plant and upstream connectivity via a dial-up access server that supports upstream traffic from DOCSIS-compliant telco-return cable modems connected to the Public

Switched Telephone Network (PSTN). This enables cable operators that cannot support two-way radio frequency (RF) cable transmission to offer high-speed downstream data services over cable, with upstream transmission via the PSTN. EuroDOCSIS telephone configurations are also supported.

Figure 3: Typical Small Cable Operator One-Way Application

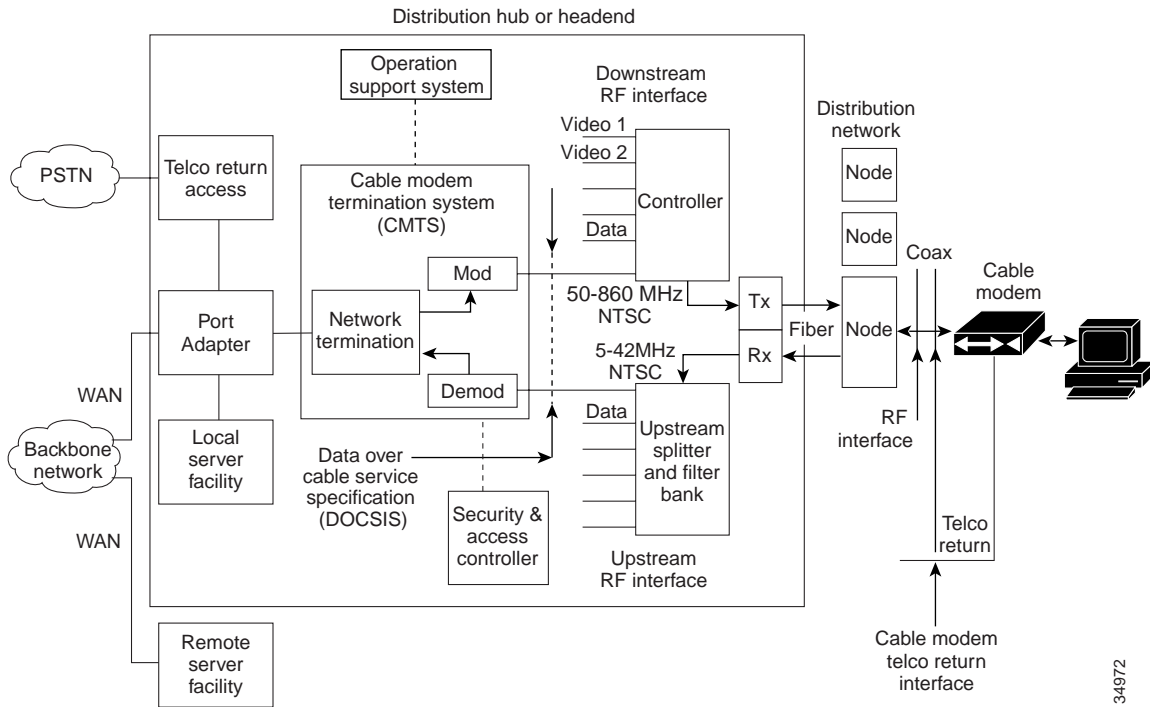

What market is the Cisco uBR7100 Series Universal Broadband Router targeted for? The Cisco uBR7100 Series is designed primarily for the MxU market. This market represents a relatively untapped opportunity to expand broadband cable service. The sheer quantity of MxU enterprises offers extraordinary possibilities and increased revenues. Given the relatively small subscriber base of an MxU setting, the challenge has been to deliver robust services quickly and cost-effectively for an accelerated break-even point and a higher return on investment (ROI). The Cisco uBR7100 Series enables this. The MxU market includes:

- Multi-dwelling units (MDUs) that include high rise and garden-style apartments, townhouses, and condominiums; more and more, apartment renters and owners are demanding high-speed Internet connections

to home offices. Owners or MDU associations can attract new buyers or renters by supporting an advanced cable IP infrastructure that delivers secure, high-speed Internet access, along with traditional cable TV service.

- Multi-Tenant Units (MTUs) that refer to commercial properties that house a number of small or medium-sized offices; this includes shopping mall consortiums. Such users can leverage the existence of a cable IP infrastructure to:
 - Use a high-speed cable broadband medium for improved internal communications, including LAN services.
 - Develop their businesses further and attract new opportunities and revenue streams through technological infrastructure advancements and introduction of new services.

- Hospitality applications that refer to hotel and lodging properties and services, as well as airports or convention centers; applications include fast Internet access, e-mail, video entertainment, or virtual private network (VPN) services. Business travelers today demand high-speed connections to the Internet, as well as access to company intranets. Enterprises with large numbers of itinerant users are willing to spend money to offer LAN-like performance and extend high-speed telecommuting to corporate users. Hospitality providers can build networks that support such services in a flexible, affordable, and transparent manner with the Cisco uBR7100 Series Universal Broadband Router. Most hotels support video on demand (VoD). Larger hotels may have several nodes that serve groups of conference rooms with VoD services. Services can be expanded to include IP-based data services. System integrators often service larger hotels. Not all hotels, however, want third-party Internet service management. Some would like to handle services directly. Cable operators can service hotels directly or pair with an Internet service provider (ISP) to meet needs.
- Universities, colleges and research institutions require Internet and intranet connections; applications here include distance learning, real-time imaging, shared

“white board” and video conferencing. Broadband support means tomorrow’s students can log on to a class and watch the professor, while study notes appear on one side of a computer or TV screen.

Cable operators can partner with ISPs to offer IP-based services to the MxU market or can serve this market directly depending on the size and complexity of applications. Cable operators can gain additional revenue from MxU opportunities. MxU business customers can differentiate themselves from their competitors and gain marketshare or recognition through new service introductions.

Figure 4 depicts a hotel application. Hotels thrive or fail based on the quality of their customer care and accommodations. Emphasis on premium guest services is particularly important at the high end. Corporate travelers and resort guests demand services and facilities that enrich visits. Corporate travelers, in fact, often need to work from their rooms, and thus, require Internet and intranet access. Travelers prefer to work as efficiently as if they were in the office.

Figure 4: Hotel Application

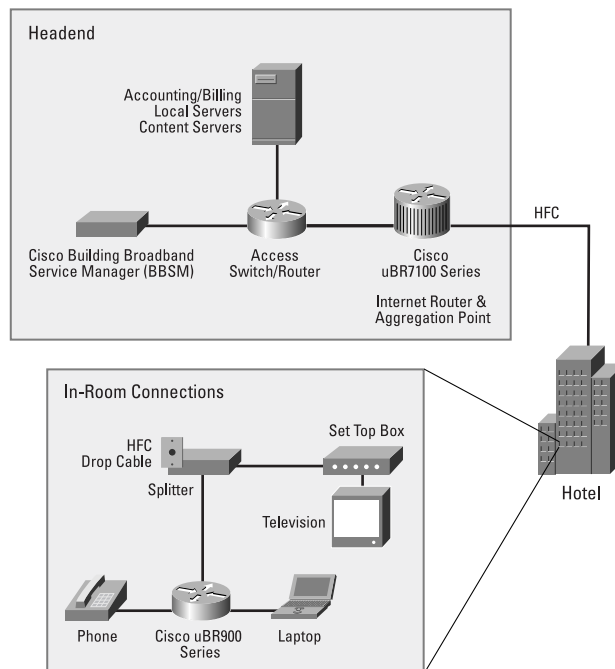

Using the Cisco uBR7100 Series to create a broadband cable network gives hotels the greatest economic advantage at the lowest cost. The hotel can deliver customized content such as local advertising, offer automated registration/check-ins, and support online payment that yields new revenues from increased customer satisfaction and repeat business. The Cisco uBR7100 Series Universal Broadband Router can be installed as an on-premises mini-headend or distribution hub. Broadband cable connections can support connectivity to multiple rooms on multiple floors. Depending on the services the hotel supports, a cable modem and laptop, as well as a set top box and TV can reside in each room.

Figure 5 shows a shopping mall application. Shopping is already a proven Internet convenience. Businesses can entice consumers to the mall and converge online and offline retailing. The Cisco uBR7100 Series can be installed as an on-premises mini-headend or distribution hub to support high-speed services that improve the bottom line. Individual stores within the mall can be wired to support cable access. A full-service shopping center owner and property manager—specializing in shopping center development, financing, and property acquisition and disposition—can build an IP cable broadband network that supports a variety of high-speed communications and value-added interactive services to retailers.

Figure 5: Shopping Mall Application

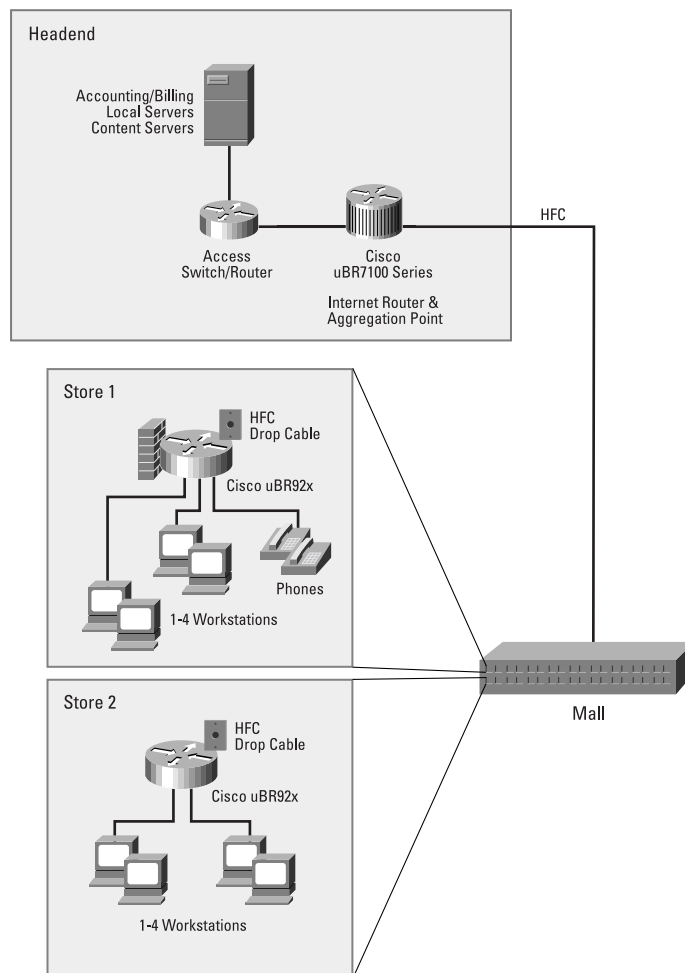

This enables retailers to offer the benefits of high-speed connectivity using the latest data and video communications tools. Benefits are both external such as live fashion shows that enrich the mall visit and internal such as e-learning for new employee training, warehouse inventory checks and placement of orders to replenish stock, and improve closing of finances by linking retail outlets to headquarters.

Figure 6 depicts a convention center application. Competition to entice firms to hold meetings at particular facilities is often fierce. One way to attract business and differentiate services is to offer an expanded list of new IP-based services. The Cisco uBR7100 Series is again installed as an on-premises mini-headend or distribution hub. Cable modems and PCs are found in different meeting rooms. The figure shows how Internet and intranet access can be achieved in an extended office network environment.

Figure 6: Convention Center Application

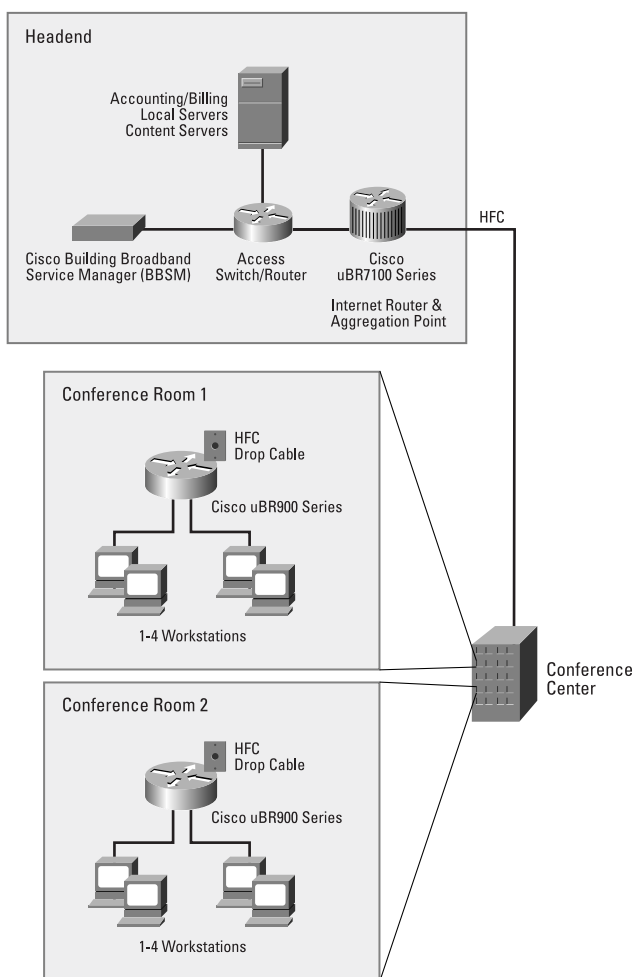
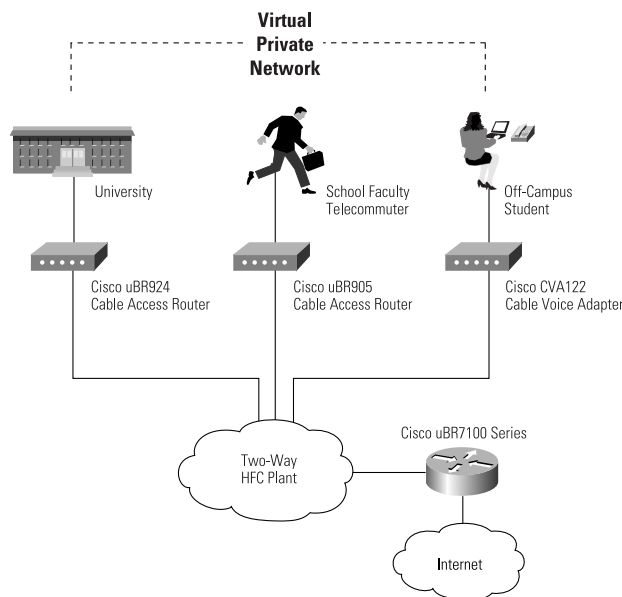

Figure 7 depicts a distance learning application. Broadband cable gives educational facilities the capability to support online, real-time education. Cable operators can contribute to the community, while driving demand for broadband cable access. In this application, the Cisco uBR7100 Series Universal Broadband Router serves as a

on-premises mini-headend or distribution hub. Cable modems and PCs reside at a university, remote telecommuter faculty location, or an off-campus student site. Using multicasting technology, a professor can reach students at many different locations simultaneously.

Figure 7: Distance Learning Application



As shown, the Cisco uBR7100 Series Universal Broadband Router supports a wide variety of applications. Because the product is designed with current and emerging standards in mind, cable operators do not have to fear their systems will become obsolete. The product interoperates with a wide variety of DOCSIS and EuroDOCSIS compliant vendor equipment, and therefore, offers the best alternative when delivering Internet access and other IP services to residential subscribers or when serving the MxU market.

Features and Benefits

Cost-Effective Integrated DOCSIS- or EuroDOCSIS-Based CMTS and Powerful Cisco IOS Router

The Cisco uBR7100 Series combines the functions of a traditional high-end router with a CMTS that contains an integrated upconverter/modulator—all, in a cost-effective bundle. The Cisco uBR7100 Series leverages the industry-leading Cisco uBR7200 Series and uses powerful Cisco IOS software. This enables operators to benefit

from the continual growth and enhancement of flagship Cisco hardware and software. Providers can gain the advantages of high-performance network-layer switching and services, including security, QoS, and traffic management. The Cisco uBR7100 Series meets requirements for high-speed online access at an affordable price.

Standards-Based

The Cisco uBR7100 Series is designed to provide a standards-based platform. The product enables cable operators to install equipment today with the assurance that future technological improvements are accommodated. Adherence to standards such as DOCSIS or EuroDOCSIS ensures interoperability with a wide variety of compliant CPE devices.

Flexible, Easy-to-Use, All-Inclusive Product Design

The Cisco uBR7100 Series offers maximum flexibility. The product supports two-way and telephone return based on the Cisco IOS Software ordered.

The product supports Simple Network Management Protocol (SNMP) for standards-based network management. Other configuration options include Telnet and serial access via console or auxiliary port connections.

The Cisco uBR7100 Series ships with Cisco Network Registrar version 3.5 at introduction. Cisco Network Registrar provides policy-based, robust, and scalable Domain Name System (DNS) and Dynamic Host Configuration Protocol (DHCP) services that form the basis for a complete cable modem or set top box provisioning system. Cisco Network Registrar is used both as a standalone product and as a component of the Cisco Subscriber Registration Center (CSRC).

The Cisco uBR7100 Series works with the Cisco Building Broadband Service Manager (BBSM) system which offers an integrated, single-vendor MxU solution. Together, the Cisco uBR7100 Series and the Cisco BBSM deliver a cable-based in-building platform that supports plug-and-play Internet access, self-service activation, tiered service levels, and integrated billing. BBSM uses Network Address Translation (NAT) to connect static IP configurations and DHCP for dynamic configurations. The Cisco BBSM links to MxU property management systems (PMS) to support tiered services and remote port-by-port manageability.

Troubleshooting Tools and Commands

The Cisco uBR7100 Series supports troubleshooting with detailed traffic statistics by protocol and IP address.

Available troubleshooting commands include two key areas to diagnose problems:

- **Cable modems and the cable plant**—Cisco uBR7100 Series software includes a flap list command that helps isolate problems between the cable plant (such as ingress noise or incorrect power levels) and specific cable modems. A flap is defined as a cable modem being registered on the CMTS, deregistering, and then immediately reregistering. With the flap list, operators can quickly learn how to characterize trouble patterns in the network, determine which amplifier or feeder line is faulty, distinguish an upstream from downstream path problem, and isolate an ingress noise impairment from a plant equipment problem.

- **Transmission Control Protocol/Internet Protocol (TCP/IP)**—The system supports tracing and debugging DHCP related messages on an administrator-defined CMTS network interface; tracing and debugging all Media Access Control (MAC) layer DOCSIS messages for a defined MAC address and monitoring specific processes through available debugging commands.

Traffic Shaping Mechanisms

The Cisco uBR7100 Series allows operators to specify policies to handle traffic exceeding bandwidth allocation. The product offers traffic-shaping capabilities to limit the data rate to and from a cable modem. Given that cable is a shared medium, rate limiting ensures no single cable modem consumes all of the channel bandwidth. Rate limiting also ensures that operators can configure different maximum data rates for cable modems. Subscribers requiring higher peak rates and willing to pay for this can be configured with higher peak rate limits over regular subscribers who pay less and get lower rate limits.

The Cisco uBR7100 Series reduces the chance that data must be retransmitted to hosts on the cable plant. When rate limiting cable modems on the network, the Cisco uBR7100 Series software typically drops packets to enforce the rate limit. Dropping packets from a requesting cable modem causes the host sending the data to retransmit. Retransmitted data wastes bandwidth on the network. If both the hosts sending and requesting data are on the cable plant, the upstream bandwidth is wasted as well. The Cisco traffic shaping feature delays the scheduling of the upstream packet which in turn causes the packet to be buffered on the cable CPE device, instead of being dropped. This allows the user's TCP/IP stack to pace the application traffic appropriately and approach throughput commensurate with the subscriber's defined QoS levels.

Guided and Scheduled Spectrum Management

The Cisco uBR7100 Series supports all DOCSIS and EuroDOCSIS error correction encoding, modulation types, and formats. The DOCSIS and EuroDOCSIS RF specifications define the communications paths between the Cisco uBR7100 Series and cable modems on the network. The Cisco uBR7100 Series offers options that

allow operators to specify different rules the system uses when encountering noise on the cable plant. Frequency hopping is one option in which upstream frequencies can be assigned as fixed or in a subband, and a hopping-decision criteria specified.

Reliability

The Cisco uBR7100 Series offers exceptional reliability. A PCMCIA Flash memory card enhances reliability by storing backup software images and configuration files. Environmental monitors offer levels of escalation so that you can take corrective action prior to a system shutdown.

Cisco uBR7100 Series Universal Router Features and Benefits

Feature	Benefit
Complete package including a combined router and CMTS with an integrated upconverter and embedded network interface	<ul style="list-style-type: none"> • Offers the lowest capital cost for an initial entry point with the most features • Reduces hardware costs • Minimizes overall cost of deployment
Standards-based	<ul style="list-style-type: none"> • Protects investment and ensures operability with a wide-set of CMs and STBs
Easy deployment	<ul style="list-style-type: none"> • Allows single, centralized point of administration • Includes tools to provision hosts/CMs and supports Property Management Systems (PMS) to quickly build and deploy a service-enabled broadband cable network today that generates immediate revenue
Reliable	<ul style="list-style-type: none"> • Ensures reliable service • Enables servicing to be quickly and easily performed, minimizing downtime and impact to the network
Advanced SNMP network management	<ul style="list-style-type: none"> • Enables identification of trouble areas before impacting customer service • Reduces response time in the event of a failure

Distributed by: Mega Hertz 800-883-8839 sales@go2mhz.com www.go2mhz.com