

edje[®] 4000

Real-Time Streaming AVC Encoder

Supporting IPTV platforms, the edje-4000 provides unmatched value and provides the amenities of encoders costing five times its price and measuring four times its size - finally an IPTV AVC encoder for the masses!



The edje4000 is a real-time streaming MPEG 4 Part 10 (AVC) encoder. AVC/H.264 supports many profiles and layers making it useful across markets including Satellite and Cable distribution, Telco and Broadband TV, high quality security, surveillance and Mobile applications.



applications

- Internet Protocol TV (IPTV)
- Broadband TV (BBTV)
- Satellite Direct To Home Distribution
- Next generation Cable Distribution
- Terrestrial ATSC (US), DVB-T (Europe)
- Terrestrial DMB (China)
- Backhaul
 - Distribution
 - Contribution
- High Quality Surveillance

benefits

- **Real Time high quality AVC Video Encoding:** Encode and deliver the highest quality AVC video and AAC-LC for delivery over IPTV, Satellite, Cable, and Terrestrial networks.
- **Professional video and audio inputs:** Like all previous Adtec encoders, the edje4000 provides broadcast quality video and audio inputs including Composite and SDI with pre-processing balanced analog and embedded audio via SDI.
- **Next Generation Pre-Processing:** Composite and optional SDI inputs are routed through a time base correcting video pre-processing block that removes spatial noise, temporal (motion) noise and generally improves encoding efficiency. Analog Audio levels from analog and SDI embedded audio can be adjusted via software.
- **AAC- Low Complexity (ACC-LC) audio:** The AAC-LC CODEC is significantly more efficient than MPEG 1 Layer 2 (Musicam) or Layer 3 (MP3) audio. Deliver the highest fidelity stereo audio with AAC.
- **Reliable Operation:** Adtec has delivered over sixty thousand embedded media devices globally. The edje4000 continues that legacy offering value and performance unmatched in the industry.

availability

edje 4000 is available as a 1/4 RU Streaming Encoder with mediaControl application.

- **Embedded Performance:** With a boot time and transport egress of less than 5-seconds, large computer based encoders simply can not match the high availability Adtec devices offer.
- **RS422 Device Control:** Industry standard RS422 (9 Pin) device control supporting Sony protocol. Optional
- **Live capture:** Add an optional hard drive and capture live video and audio. Optional
- **Encapsulated UDP and RTP Streaming:** The edje4000 supports raw UDP or Real Time Protocol (RTP) unicast and multicast transmission utilizing encapsulated MPEG2 transport stream format containing AVC Video and AAC Audio payloads.
- **MPEG 2 Transport, AVC and AAC CODECS:** The edje4000 provides a stable MPEG 2 Transport Stream with AVC video and AAC-LC audio payloads. MPEG 2 Transport is universally compliant with distribution and storage requirements used by MPEG, SCTE, DVB, ATSC and DMB standards. Very stable Jitter, rock solid AV Sync, CODEC payloads, ancillary data and tables are delivered via an industry standard Ethernet interface.
- **Manage Content:** The included mediaControl application allows you to configure, encode and deliver the highest quality video and audio for your application.

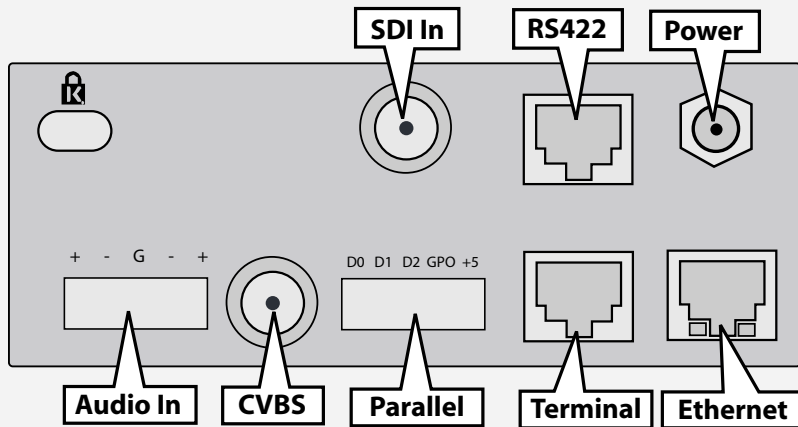

What is AVC?

H.264, MPEG-4 Part 10, or AVC (for Advanced Video Coding), is a digital video codec standard that is noted for achieving very high data compression. It was written by the ITU-T Video Coding Experts Group (VCEG) together with the ISO/IEC Moving Picture Experts Group (MPEG) as the product of a collective partnership effort known as the Joint Video Team (JVT). The ITU-T H.264 standard and the ISO/IEC MPEG-4 Part 10 standard (formally, ISO/IEC 14496-10) are jointly maintained so that they have identical technical content. The final drafting work on the first version of the standard was completed in May 2003.^[1]

specifications

Video Input

Composite (BNC)

Optional Video Input

SDI (BNC)
 - (SMPTE 259M)
 Embedded Audio
 - (SMPTE 272M)

Pre Processing

Provides exception low bit rate performance
 MCTF
 Median Filter
 Time Base Corrector
 Edge Sharpening Filter

VBI Support

Line 21-Closed Captioning
 ATSC A53/D
 Teletext WSS PAL

Video Encoding Profile

ISO/IEC 14496-10
 - (MPEG 4 Part 10 or AVC)
 Progressive Base Line profile L3
 Interlaced Main Profile L3
 - (no B frames or CABAC in Main)
 CBR/VBR
 Quarter-Pel Motion Estimation
 - (4x4 mode)
 Deblocking Filter

Video Encoding bit rates

300 kbps -5 Mbs

Video Resolutions

176 x 120 to 720 x 480 NTSC
 176 x 120 to 720 x 576 PAL

Multiplexing Formats

ISO/IEC13818-1 MPEG 2 Transport Stream

Streaming Format

ETSI TS 102034

Audio Inputs

24 Bit A-D Conversion
 Audio Level Control
 - (Analog and SDI Input)
 Two channels Balanced
 - (RST-5 Pin)
 SMPTE 272M
 - (Embedded with SDI Option)

Audio Encoding Profiles

AAC-Low Complexity

Audio Sampling

32, 44.1 and 48 KHz

Audio Bit Rates

8-384 Kbs AAC-LC

Ethernet

10/100 (RJ-45)
 Half Duplex
 Full Duplex
 Auto Negotiate

Ethernet Protocols

Telnet
 FTP
 UDP
 RTP/UDP
 SDP and SAP support

MPEG Table Compliance

PAT and PMT

DVB Table Compliance

SDT, NIT, TDT (TOT)

User defined Program Identifier (PID)

PMT
 Video (PCR on video)
 PCR (Separate if desired)
 Audio
 SI and PSI Tables

Serial Communications

Terminal RS232
 - (38400-115,200K, 8, 1 N)
 Com2 RS232/RS422/RS485
 - (9600-115200 K, 8, 1 N)

Parallel Control and Tally

5 Pin Removable Screw Terminal
 3 Data Inputs
 - (User definable)
 1 Data Output
 - (User definable)
 Ad Insertion Cueing
 SCTE 35
 SCTE-104

Power

12 VDC less than 24 watts (2.5 MM locking)

Physical

4" wide, 10" deep, 1.70" tall

what's included

- edje4000 Real-Time Streaming AVC Encoder (PN: edje4000)
- 12 VDC external power supply and power cable (USA) (PN: EXTPS24WATTKIT)
- mediaControl application control & configuration software for Windows 2000/XP or Macintosh OS X (10.2 or greater).
- Connection Kit: Ethernet cable and serial 9 pin adapter (PN: TERMINALKIT2)
- Two Audio Plugs (PN: AUDIO5PINPLUG-S)
- Manual (PN: CAT-017)

options

RackShelf w/Hardware: Holds 4 edje 4000 encoders, power supplies and provides cable ties slots (PN: 200-024-1AKIT)

edje4010: Adds optional SDI video with embedded audio (PN: edje4010)

Distributed by: Mega Hertz

800-883-8839 sales@go2mhz.com

www.go2mhz.com

Note: Specifications subject to change without written notice

© 2007 Adtec Digital. Product and company names may be trademarks or registered trademarks of their respective companies. edje® is a registered trademark of Adtec Digital. Other product and company names may be trademarks or registered trademarks of their respective companies. This information may not, in whole or in part, be copied, photocopied, reproduced and translated, or reduced to any electronic medium or machine-readable form without prior consent in writing from Adtec Digital.

[1] From Wikipedia <http://en.wikipedia.org/wiki/H.264>